

# Intelligently controlled. Precisely profiled. Four-sided solution.

**HC HOMAG**

**Our Planing and Moulding Machine**  
MOULDTEQ M-300

**YOUR SOLUTION**



## Prepared for the future

With the MOULDTEQ M-300 the days of the push buttons are over. The planer combines state-of-the-art technology with solid mechanical engineering. In this way, you get intuitive machine operation and maximum quality in one machine and you will be optimally prepared for the future.



**5-8** spindles with variable feed speed.

Variable spindle speed from 2nd spindle onwards of

**4,000-8,000** rpm for optimal workpiece quality.

Workpieces with **300** mm length possible.



**Ergonomic remote control** for quick and automatic adjustment of selected spindles



**HOMAG powerTouch2** – ease of use for the next generation



**Workpieces** from 300 mm length onwards



**Maximum comfort** through mobile control panel



**Axial adjustment** range up to 75 mm

## Highlights

- Flexibility thanks to variable feed and variable spindle speed
- Intuitive machine operation via powerTouch
- Quick set-up with proLock spindle clamping system
- High precision due to cast iron frame
- Ideal power transmission, each spindle is driven by its own motor

## From four-sided planing to complete profile processing

The workpiece is guided by linear ruler through the machine and held in place by pressure rollers. Through diverse tools, our clients have the ability to even profile or saw the workpiece during the moulding process.

## Applications

### 5 SPINDLES

IDEAL FOR CARPENTRY SHOPS



### 6 SPINDLES

IDEAL FOR WINDOW, DOOR AND PLINTH MANUFACTURING



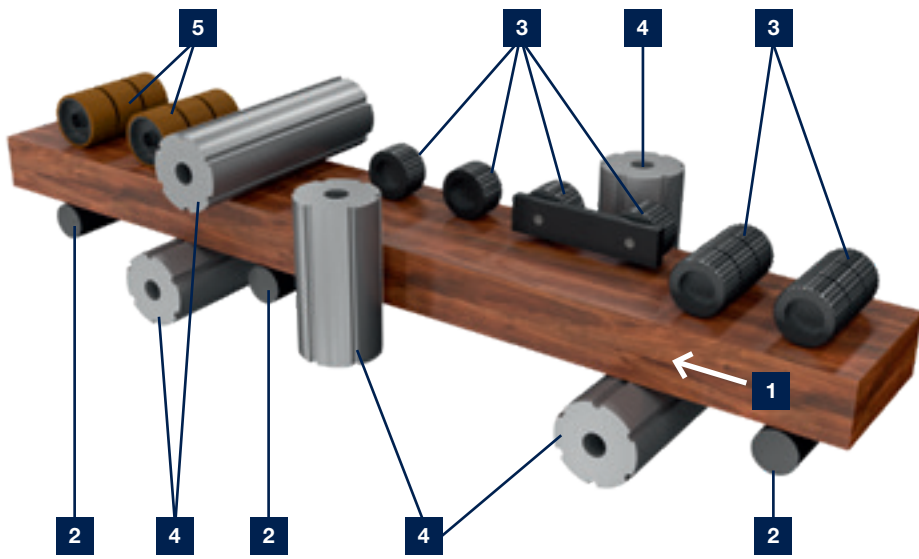

- 1** Throughfeed direction
- 2** Driven rollers
- 3** Power driven top pressure steel rollers
- 4** Spindle with planer head
- 5** Top pressure rubber rollers

## 7 SPINDLES

IDEAL FOR WINDOW, DOOR AND PLINTH MANUFACTURING WITH EXTENDED PORTFOLIO



## 8 SPINDLES

IDEAL FOR WINDOW, DOOR AND PLINTH MANUFACTURING WITH EXTENDED PORTFOLIO





## The Details

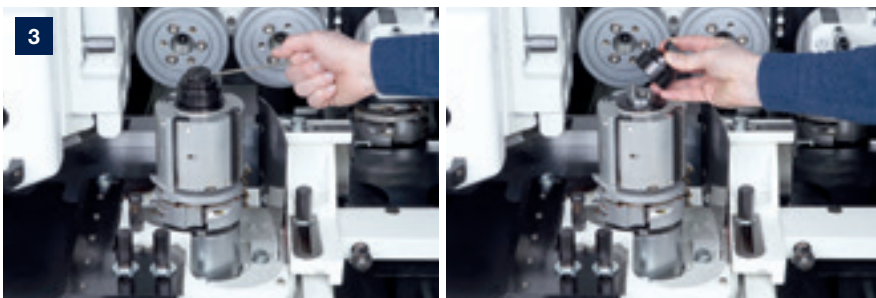
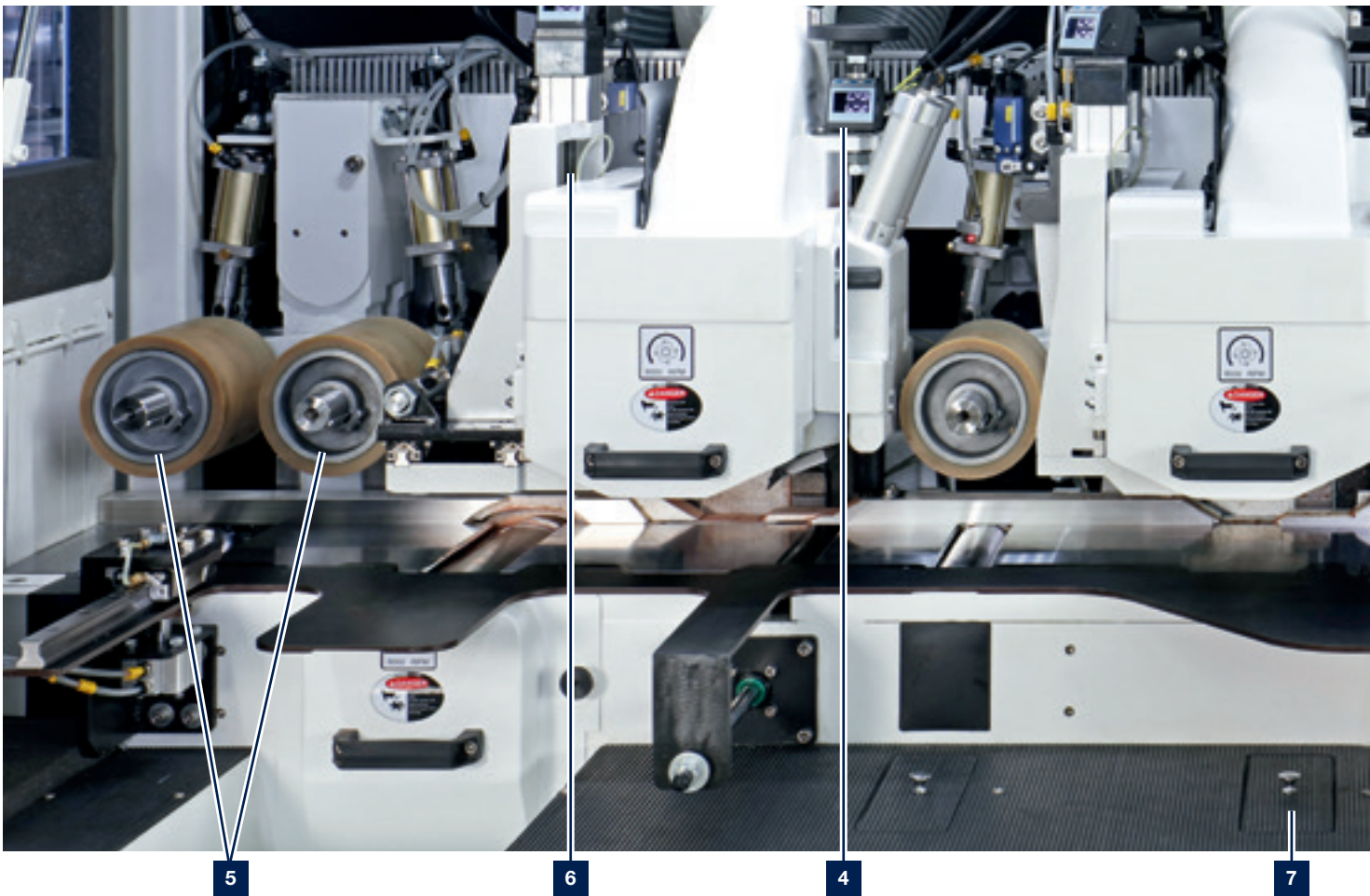

**Quick and easy tool change** with proven proLock tool clamping system



**Review radial position of tools** via electronic display including target value



**Harden chromed feeding table** for long lasting service life

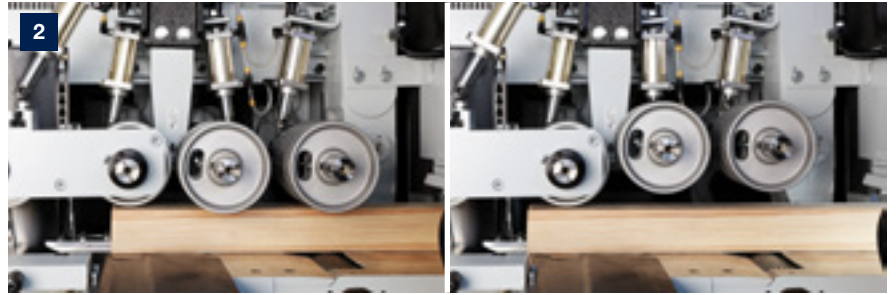

**Pneumatic adjustable top feed rollers** for optimum contact pressure for different profiles and types of wood (left activated, right deactivated feed rollers)

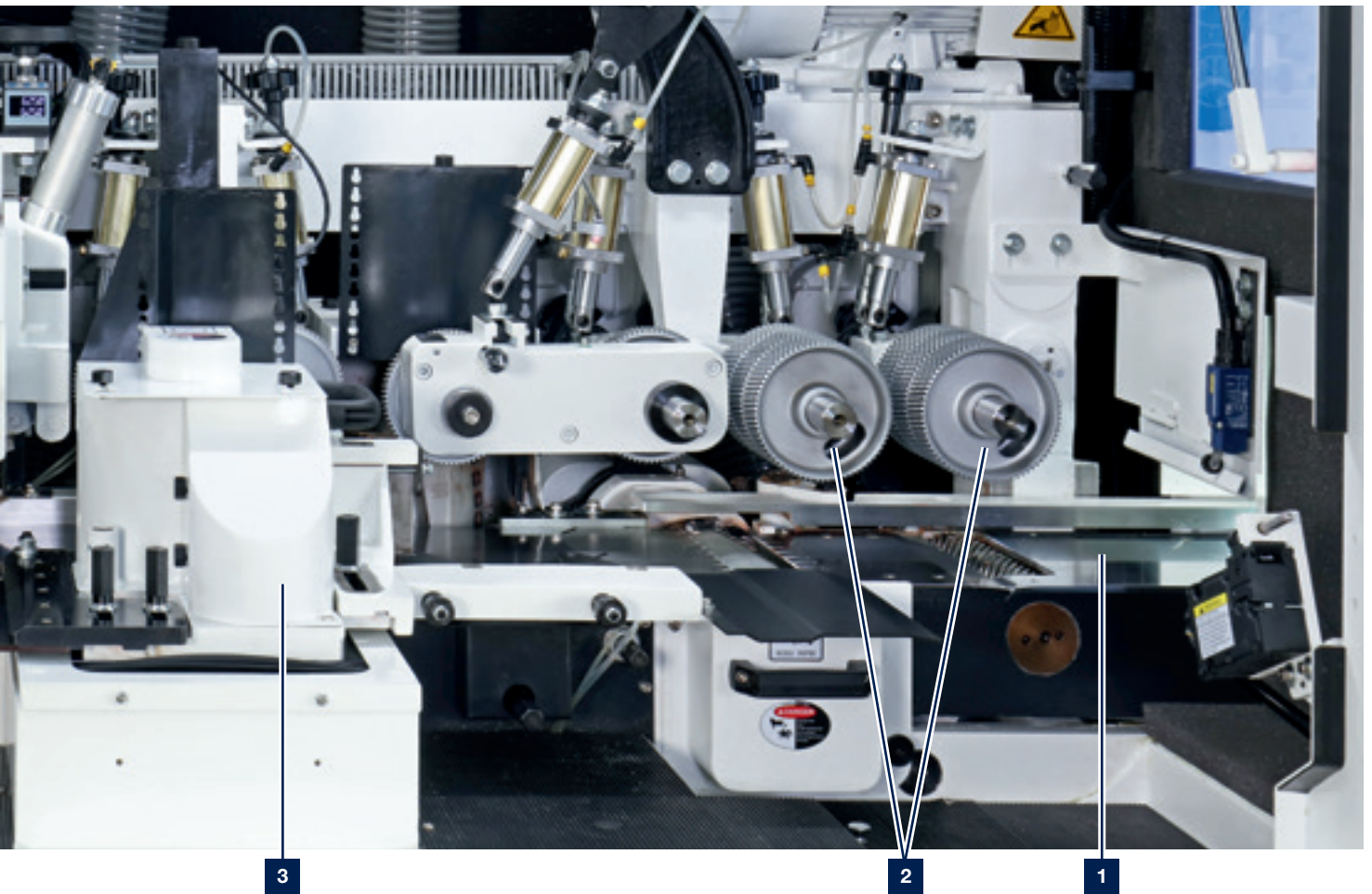

**Top pressure rubber rollers** for sensitive surfaces after processing (Shore hardness: 80)



**Linear guide** for precise adjustment of the top spindles and optimal work piece quality



**Accessible central lubrication** at machine front



# Automation

Various automation solutions for our moulders ensure that waiting times are minimized and processes can be made more efficient.



## Return

- No training required – install, connect and get started
- Flexible personnel organization – thanks to cost-effective single-person operation
- Ergonomic working – manual parts handling is reduced to a minimum
- Improved quality control – rapid response to material adjustments

## Your benefits at a glance



**Minimized  
waiting time!**

**40%**

**Your processes  
become more  
efficient by up  
to 40%!**





- 1 Infeed
- 2 Processing
- 3 Outfeed
- 4 Return

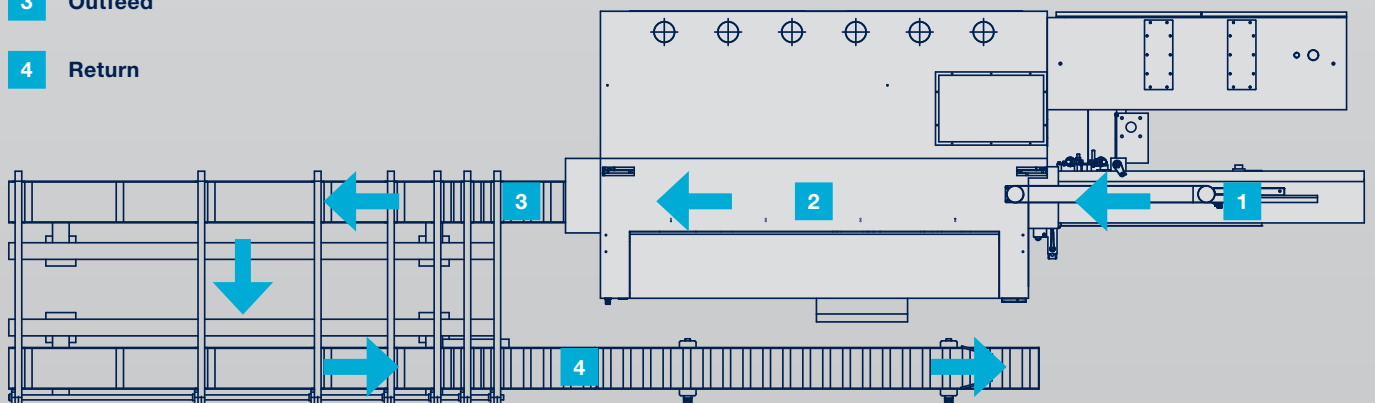

## Option – Universal spindle

On each normal spindle configuration there's the possibility to add a universal spindle at the end. This spindle is 360° moveable and offers the possibility to be always on the right place, where you need it the most. If you need frequent changes to multiple spindle configurations, this is the best option for you.

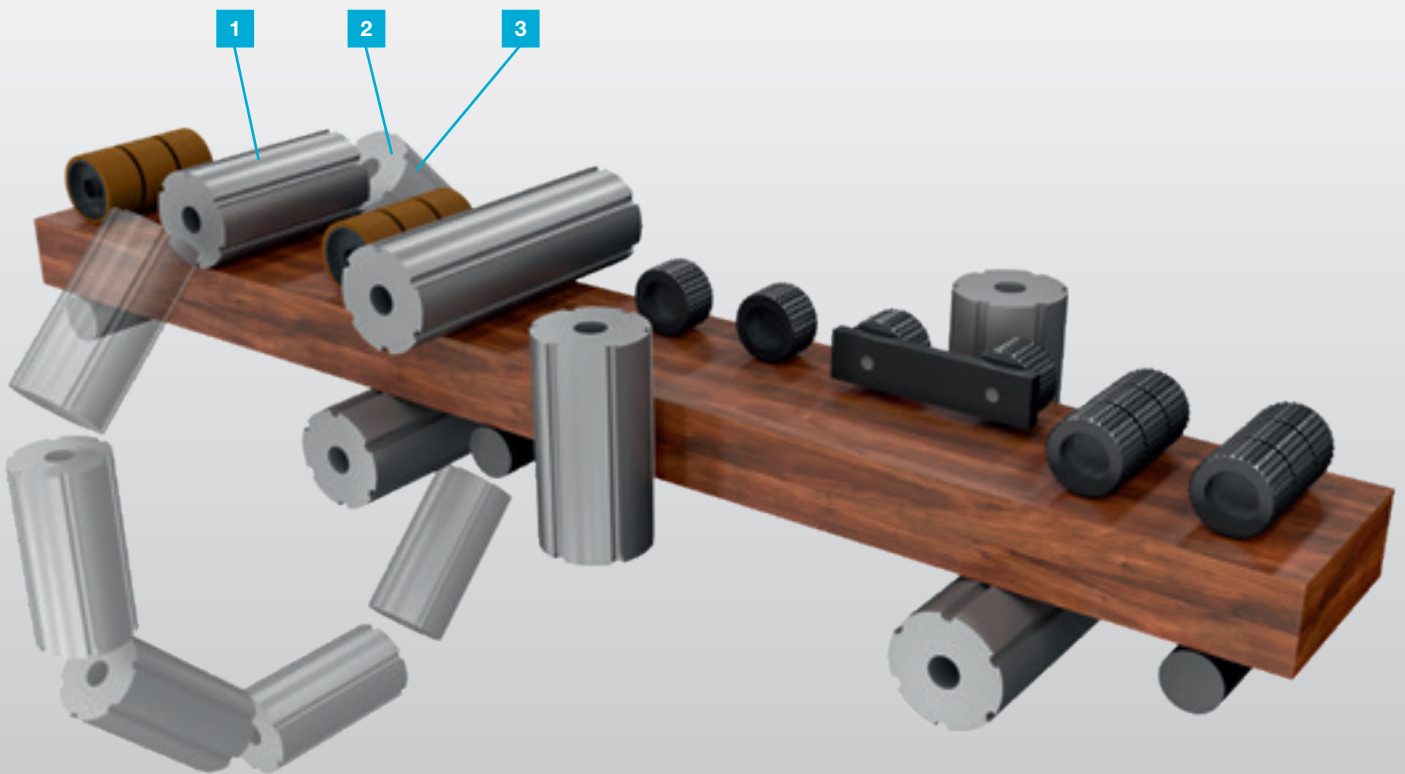

Usage as top spindle



Inclined spindle + cutter head



Inclined spindle + saw

# Options

**WOULD YOU LIKE SOMETHING EXTRA?** Our options provide optimal customization solutions for your planing and moulding needs.



## Grooved machine table

Before the first bottom spindle, a special profile cutter head moulds grooves into the workpiece. A grooved bed may be the best solution to keep the work pieces from moving side to side. Thus, providing a very accurate finished product as required in wood component and furniture part processing. On the last bottom spindle the grooves in the workpiece get planed away. The grooved machine table can be used for short or curved pieces.



## Telescopic feed roller opposite the left spindle

Depending on the requirements to move the position of the feed rollers. If there is a high variance of profiles or workpiece widths, this option provides a fast and efficient solution.



## Further options

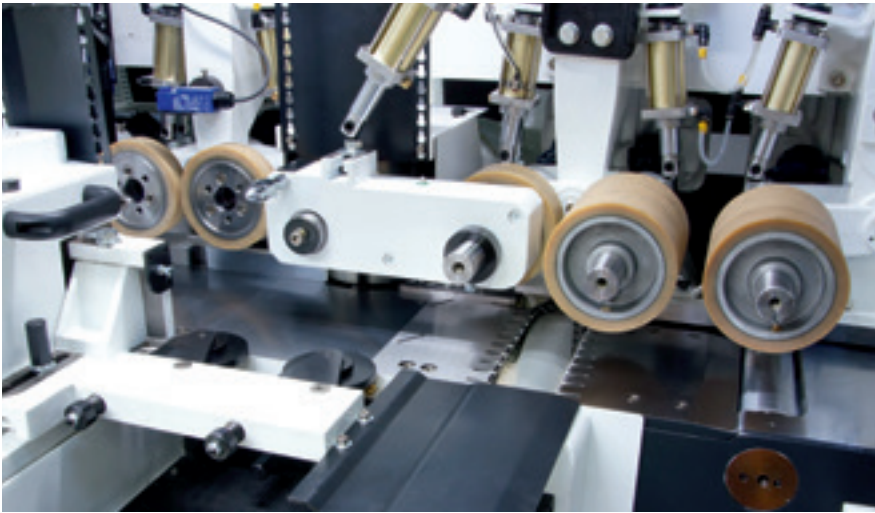

### Rubber rollers in the infeed area

Smooth feed rollers in the entire machine prevent pressure points on the workpieces and ensure gentle processing of the material. This is particularly important when little or no material is planed off the top spindle and the classic feed rollers would leave pressure marks due to their corrugation.

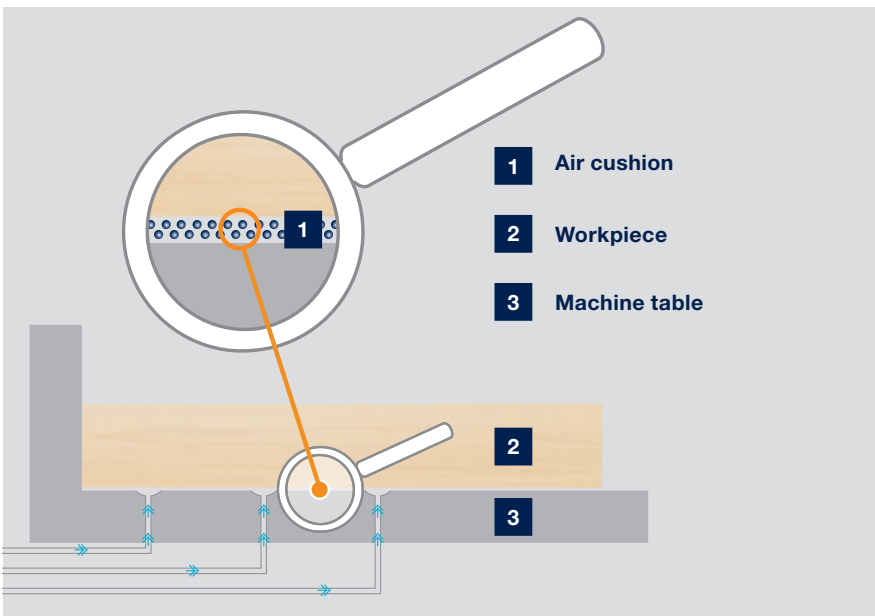

### Air cushion table

An air cushion is created between the workpiece and the machine table to ensure smooth transport of wet or resinous workpieces.

# HOMAG intelliMoulding

The digital multifunctional tool for all operators of a planing and profiling machine.

The intelliMoulding App supports the operation of a planing and profiling machine. The app provides various digital tools that are precisely tailored to the requirements of a planing and profiling plant. The aim is to minimise errors, make production more efficient and tap new optimisation potential. The intelliMoulding App is suitable for employees in craft or industrial enterprises.



## Knife marks

With the intelliMoulding App, the planing stroke range can be calculated from the specified machine parameters or you specify the desired planing stroke width and have the necessary machine parameters calculated.



## Production volume

From data such as workpiece dimensions, feed rate and working time the app calculates the number of workpieces produced per day, per week and per month.



## Suction volume

Easily and conveniently determine the extraction volume of a planing and profiling machine.



## NEW

The intelliMoulding App is your perfect companion for everything concerning moulding. Download the app from your store today!



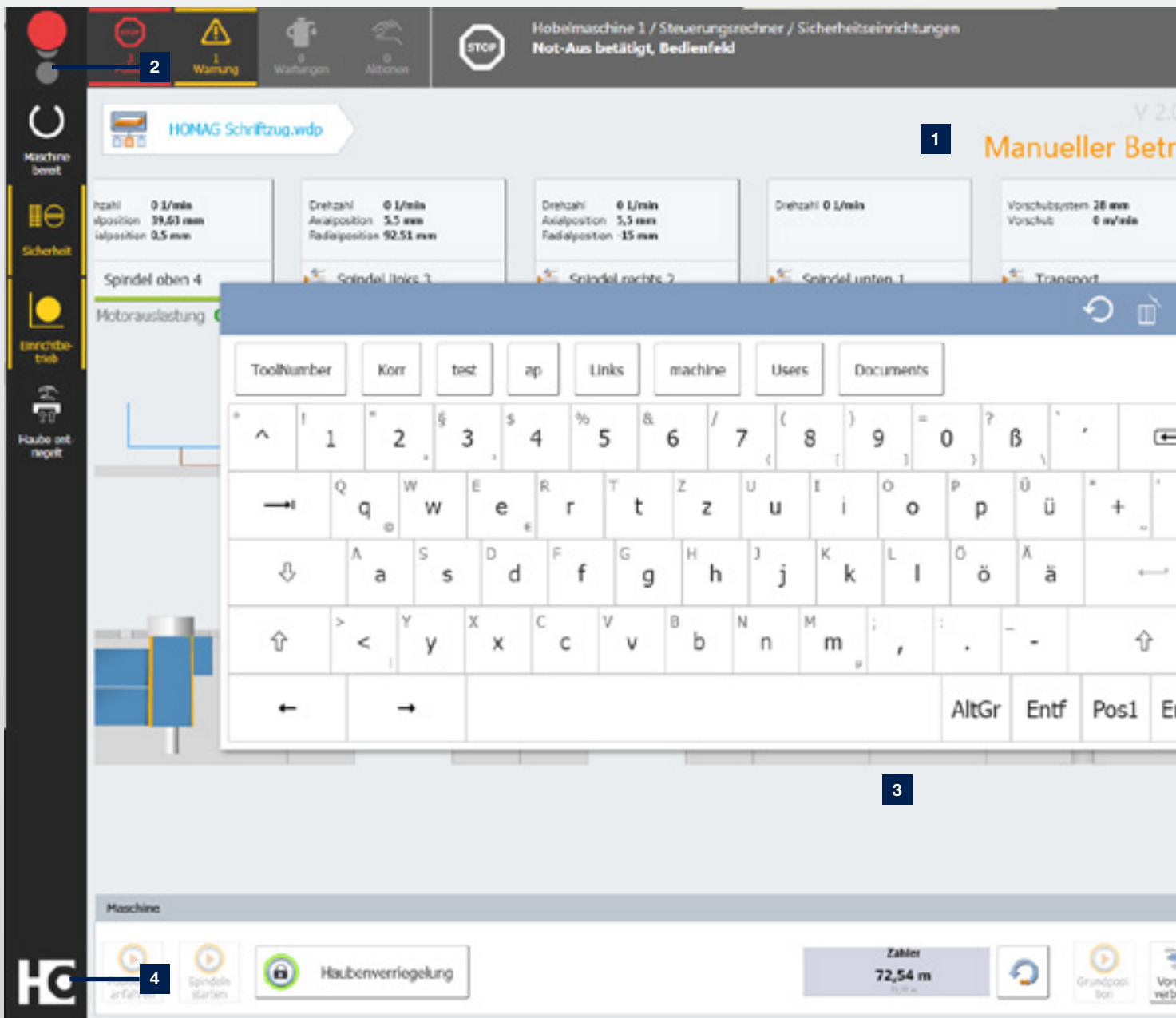

**1** The powerTouch2 screen is clearly structured. You can see all the important information at a glance, but you still have all the details.

**3** A functional pop-up keyboard that can be kept open, including automatic word completion for faster entries (when you enter the first letters, frequently used applications are proposed and you can select them directly).

**2** We have also improved the traffic light dialog further. You can now directly influence the machine's production readiness by selecting actions via the traffic light icon.

**4** Enhanced "Start" menu with additional information displayed (e.g. an indication of how many messages are currently pending or status bars that show the progress of the application) and direct access to actions (e.g. confirmation of actions without having to jump to the application).



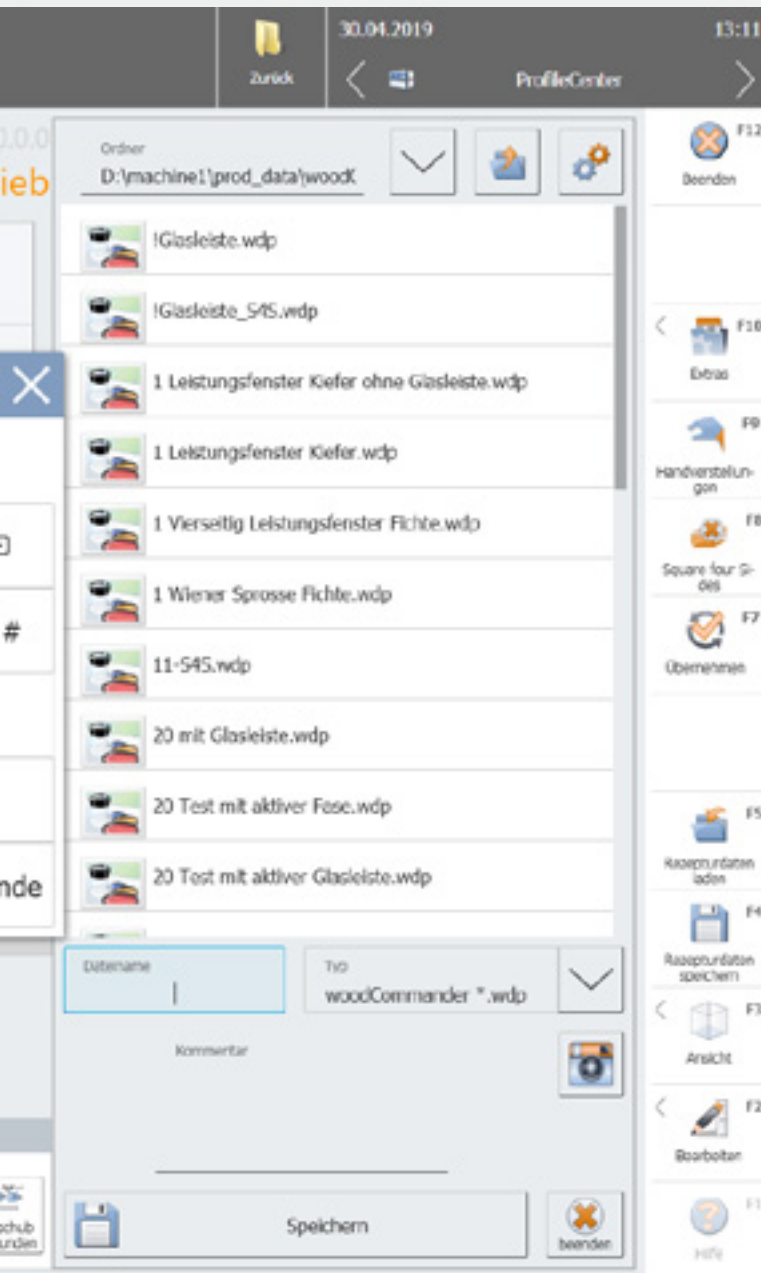

## The next generation of powerTouch: **powerTouch2**

Faster, more comfortable, clearer: Enjoy the benefits of our further improved powerTouch user interface. We have optimized our standardized operating concept and further adapted it to our customers' requirements. Controlling your HOMAG machines is now even faster and more intuitive. The new, modern design has a clear structure. The innovative touch operation allows you to achieve the desired result easily and comfortably.

With the new powerTouch generation, you can enter information at your machine even more quickly. Compared to the previous version, you can achieve a time saving of up to 30%. This is possible thanks to new features, such as automatic word completion, a pop-up keyboard that can be kept open and Windows-like functions, such as the selection of common actions directly via the start button.

Our successful powerTouch philosophy – **simple, standardized, ergonomic, evolutionary** – consistently advanced



### THE HIGHLIGHTS AT A GLANCE:

- Direct and efficient operation, up to 30% faster
- Clearer and more informative thanks to additional information and live illustrations instead of program icons
- New applications for operating and controlling machines and systems (e.g. NCCenter in the PC87 control system on CNC machines or woodCommander 4 on throughfeed machines)
- Fresh, attractive design, based on the new HOMAG machine design

# Control and visualization



## ProfileCenter

ProfileCenter is the user interface specially developed for planing and profiling machines. It enables the operator to program and store profiles and planing heads. The visualisation of the profile planing heads and the machine itself enables easy operation. All axes and setting values are controlled via the control is managed.



## Maintenance

The maintenance log is linked to the running meter counter of the machine, which provides the customer with precise information on upcoming maintenance. By clicking on Details, the corresponding instructions from the machine documentation can be downloaded. Longer maintenance can be planned in advance.

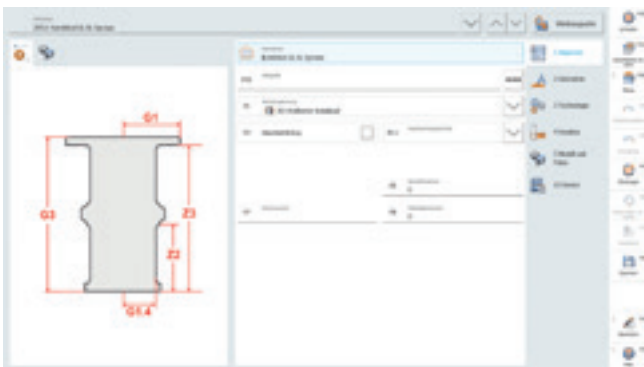

## Tool manager

All planing heads, saws and spacer rings are managed via the HOMAG ToolManager. If required, the contour of profile planing heads can also be drawn or imported.

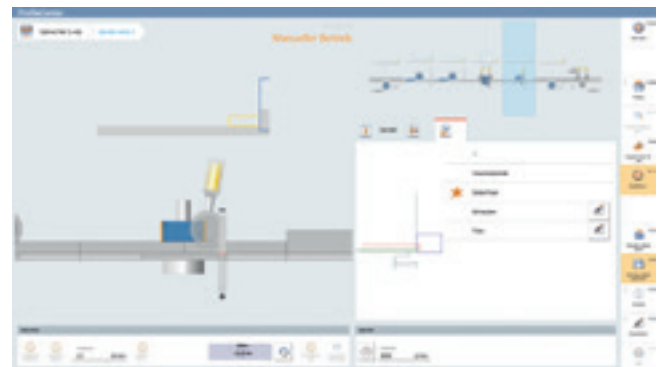

## Collision contour

The position of all components within the machine can be stored in the control to avoid collision with the planing heads. If a collision is detected, the controller reports this and does not release the positioning.



## Tapio MachineBoard MOULDTEQ

The tapio MachineBoard displays the current number of running meters and the corresponding program.

# Apps that make working life easier.

# tapio

Partner

## DataSave

- Protects machine and configuration expertise
- Faster service for machine breakdowns
- Saves time when restarting production
- Saves on maintenance costs
- Automatic backups of several machines

## ServiceBoard

- Create service cases quickly and easily and send them to the correct service partner
- Live video diagnostics to solve service cases with image support
- Video reduces the language and distance barriers
- Also works without a machine connection to tapio (and is therefore ideal for older machines)

## MachineBoard

- Push notifications
- Machine data and status can be viewed from anywhere in real time
- Lists of errors, warnings, maintenance tasks and actions
- Displays the remaining time until the next intervention by the machine operator

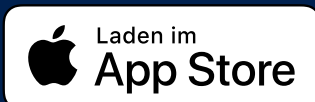

**Free demo for all tapio apps, no registration required. Simply download and test.**

## tapio is the open wood industry ecosystem

This means that everyone involved in the wood industry can participate.  
Because together with our business partners, we develop digital solutions for everyone.

Currently available in the EU and Switzerland.

(Due to the fast pace of the IT-landscape, the compatibility to the tapio platform is warranted for five years.)





For you more than...

**1,350**

service employees worldwide

**90 %**

less on-site service thanks to successful remote diagnosis

**5,000**

customer training sessions per / year

**150,000**

machines, all electronically documented in 28 different languages – in eParts

## **HC** LIFE CYCLE SERVICES

Optimal service and individual consultations are included in the purchase of our machines. We support you with service innovations and products which are especially tailored to your requirements. With short response times and fast

customer solutions we guarantee consistently high availability and economical production – over the entire life cycle of your machine.



### REMOTE SERVICE

- Hotline support via remote diagnosis by our trained experts regarding control, mechanics and process technology. Thus, more than 90% less on-site service required and consequently a faster solution for you!
- The ServiceBoard App helps to solve tasks in a fast, simple and concrete way. This is achieved by mobile live video diagnosis, automatic sending of service requests or the online spare parts catalog eParts.



### SPARE PARTS SERVICE

- High spare parts availability and fast delivery.
- Ensuring quality by predefined spare parts and wear parts kits, comprising original spare parts.
- Identify and inquire for spare parts online under [www.eParts.de](http://www.eParts.de) 24/7, or buy even faster and more comfortably in the new HOMAG Webshop eCommerce.



### FIELD SERVICE

- Increased machine availability and product quality by certified service staff.
- Regular checks through maintenance / inspection guarantee the highest quality of your products.
- We offer you the highest availability of technicians in order to reduce downtimes in case of unpredictable troubles.

**TECHNICAL DATA**

Model		5 spindles	6 spindles	7 spindles	8 spindles
Workpiece length min. (one and one piece)	mm	300			
Workpiece length min. (one piece)	mm	800			
Workpiece width	mm	10 – 250			
Workpiece thickness	mm	10 – 160   5 – 160			
Spindle speed 1st spindle	1/min	4,000 – 6,000 (var)			
Spindle speed from 2nd spindle	1/min	4,000 – 8,000 (var)			
Spindle diameter	mm / inch	40 mm   50 mm   1-1/2 inch   1-13/16 inch			
Spindle motor power	kW	5.5   7.5   11   15   18.5			
Radial spindle positioning		Target/actual value display with crank handle   automatically			
Axial spindle positioning		Target/actual value display with crank handle   automatically			
Axial adjustment range					
horizontal spindles	mm	20   40			
vertical spindles	mm	60			
with tool diameter 130 mm	mm	75			
Feed speed	m/min	6 – 24   6 – 40			
Feed motor power	kW	4   5   7.5			
Feeding table length	m	1.1   2   2.5   3			
Table design		Smooth table   Air cushion table   Grooved table			
Option packages		Window package   Saw package   Universal spindle			
Air pressure	bar	6			
Compressed air connection	inch	R 1/2			
Suction connection	mm	5x125	6x125	7x125	8x125
Suction (average)	m <sup>3</sup> /h	3,900	4,680	5,460	6,240
Suction (max.)	m <sup>3</sup> /h	6,625	7,950	9,275	10,600
Machine weight	kg	3,800	4,750	6,440	7,300
Machine dimensions					
L     Length	mm	3,950	4,500	5,385	5,550
W     Width	mm	1,900	1,900	1,900	1,900
H     Height	mm	2,145	2,145	2,145	2,145



## **HOMAG Group AG**

info@homag.com

www.homag.com



## **YOUR SOLUTION**